

The **APS-BOX range** is designed for the efficient disinfection of roller conveyors. It consists of a simple stainless steel box containing UV lamps (*). The APS-BOX is supplied with an adjustable rail frame and so the unit can be installed at the top or at the bottom of rollers. Its main function is the effective disinfection of conveyors or the products transported by the rollers. The specific design of this product makes it flexible and adaptable to any type of roller conveyor plant.

The APS-BOX range comes in different models (APSR-10014, APSR-10015, APSR-10016), depending on numbers, length and power of the lamps.



APS-BOX



Shatterproof Lamp

APSR-10014, APSR-10015, APSR-10016 Technical Data

General Information	APSR-10014	APSR-10015	APSR-10016
Total consumption	16W	32W	48W
N° Lamps	1	2	3
Lamp Life	9000 hr		
Type of Lamp (Shatterproof optional)	Low pressure type ACBI-15067 (Shatterproof ACBI-15068)		
Box Material	Stainless Steel 304		
Mounting	Top / Bottom		
Protection class	IP 54		

Power Supply	AL
Material	Thermoplastic
Protection class	IP 54
Ambient temperature range	5 – 45°C
Power supply	230 V – 50/60Hz
Lamp cable length	1 m
Power supply cable	1 m
Feed plug	No plug (standard), SCHUKO, UK

Shatterproof lamps

This lamp coverage is specially designed for our models of the top APS-BOX range. Application of this coverage does not allow the dispersion of components or materials which, in case of accidental breakage, could escape from the lamp.

ONORM AP APSR-10014, APSR-10015, APSR-10016 Drawing

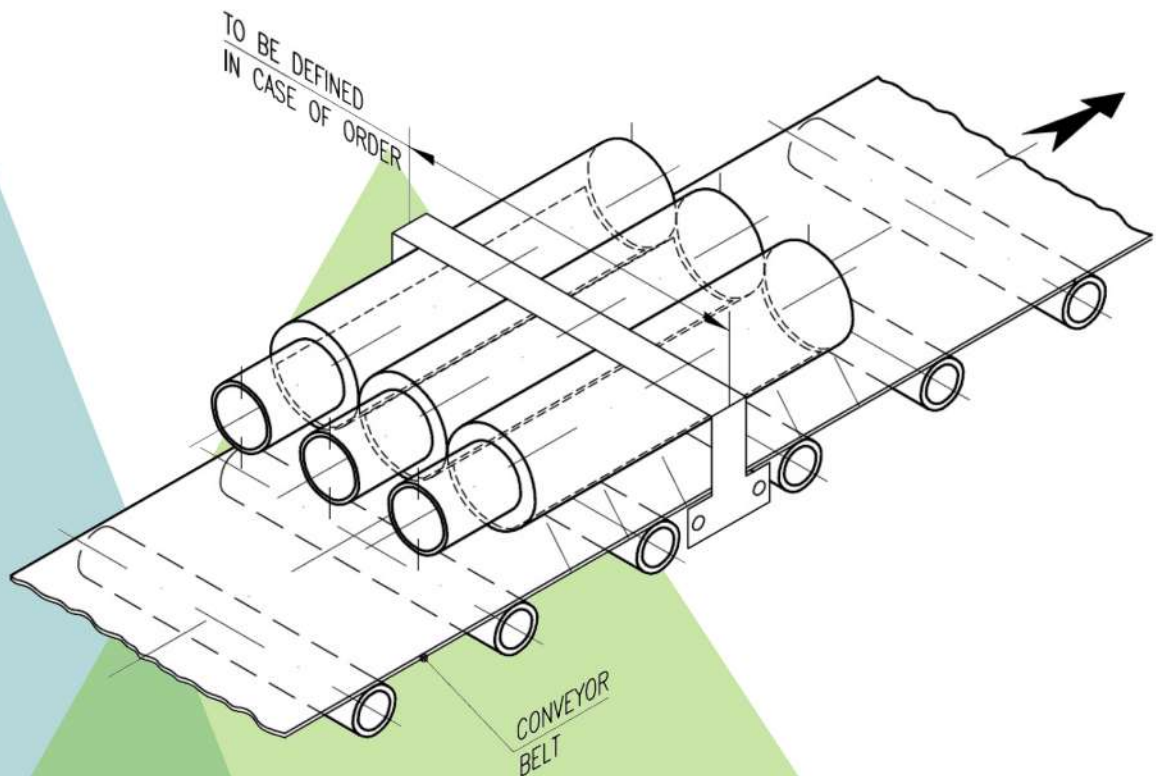
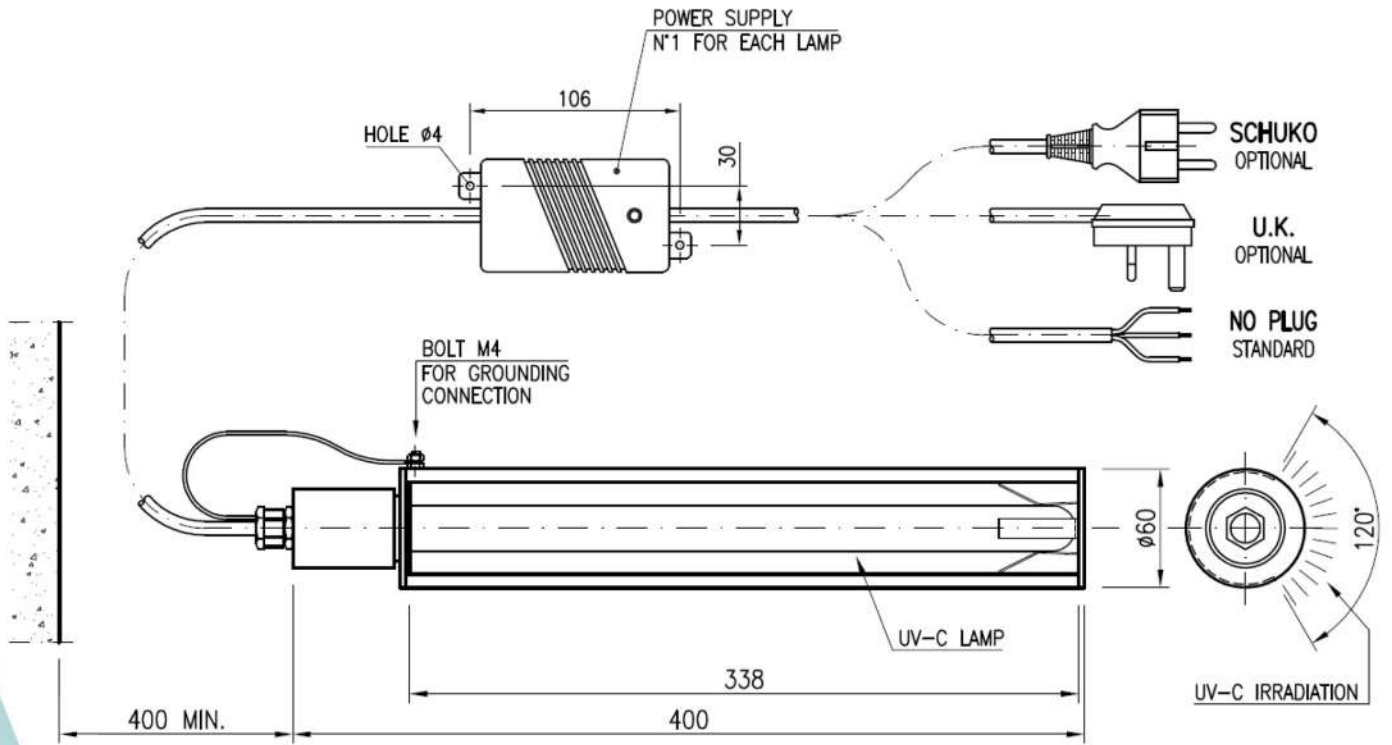

ONORM APPROVED UV SENSOR

APS-BOX Range Example of Installation

